

SV 60



Termosigillatrice semiautomatica multiformato
per vassoi, vaschette e contenitori alimentari

CARATTERISTICHE

Formato massimo 270 x 210 H. 90 mm, utilizzabile con bobina fascia 225 mm
6 formati di varie altezze selezionabili direttamente in macchina
Alimentazione 220V, assorbimento Max 650W, Temperatura di saldatura +50° + 200°,
Tempo di saldatura 0.5 / 10 secondi, Peso 30 KG, colori: bianco – inox/nero

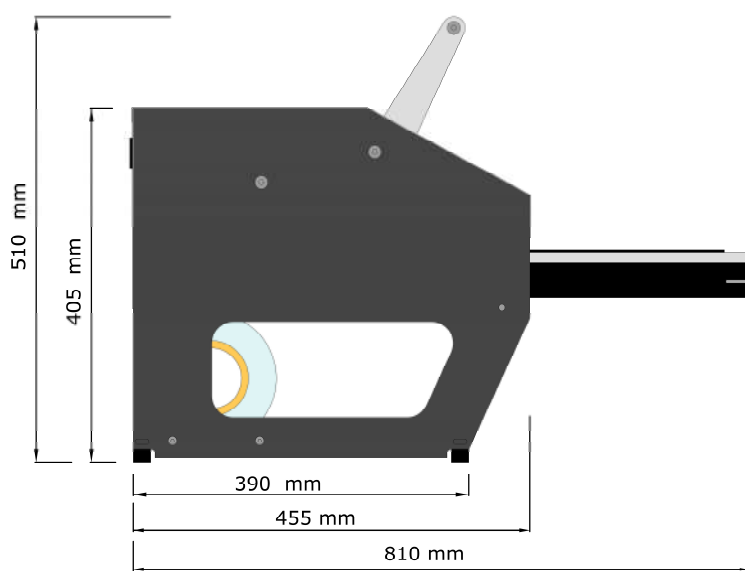

MADE IN

AUTOPAC

CONTENITORI UTILIZZABILI

Scansiona con la fotocamera il QR code dei cataloghi per scoprire tutte le possibilità di confezionamento del Sistema SV60

I contenitori appositamente studiati per il Sistema SV60 sono termosigillabili con pellicole saldanti o pelabili, personalizzabili con trattamento anticondensa o stampa a 5 colori

Vassoi in pura cellulosa Riciclabili serie "VS"

C+PAP



R-pet

Vassoi in R-Pet Riciclati Riciclabili serie "GA"



ATM
COMPATIBILE
O₂ / CO₂ / N



Vassoi in Polipropilene riciclabili Serie "G / GA"

PP



FORMATI STANDARD

Si possono selezionare sul carrello 6 formati differenti, ogni formato è disponibile in diversi materiali e altezze (misure in millimetri)

CARRELLO PRINCIPALE



MISURE SELEZIONABILI (mm)

210 X 143 - 210 X 180 - 210 X 270

SERIE : GA / VS / GA R-PET



FORMATO INFERIORE



MISURE SELEZIONABILI (mm)

137 X 95 - 137 X 137 - 137 X 190

SERIE : G / VS



ACCESSORI

Accessori studiati per aumentare l'efficienza e la praticità del sistema SV60

SUPPORTO 2B

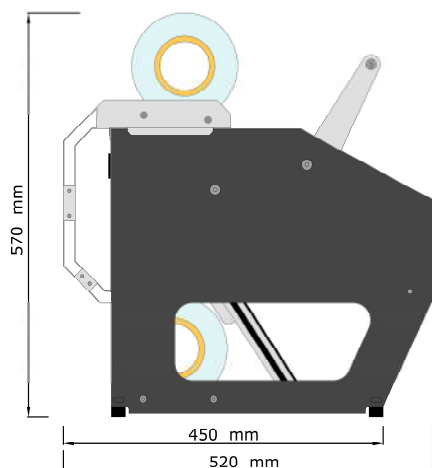

Consente l'installazione di una seconda bobina fascia 150 mm per sigillare senza sprechi di pellicola o senza l'utilizzo delle fogliette pretagliate i vassoi della Serie G e VS, misure : 137 X 95, 137 X 137, 137 X 190 mm. Il supporto 2B è installabile in qualsiasi momento senza ulteriori modifiche alla macchina.

FORMATO P

Formati realizzati su specifiche che consentono la sigillatura di contenitori diversi dallo standard SV60, come il piatto 18x18, bicchieri o altre forme geometriche, installabile senza ulteriori modifiche alla macchina.



SV60 M



Versione della macchina semiautomatica (senza leva manuale) che consente di automatizzare il ciclo di sigillatura riducendo gli sforzi e semplificando l'utilizzo. Ideale per confezionamenti in serie.
Dimensioni in mm : L. 270 H. 415 P. 455
Peso in Kg : 38,0
Da richiedere prima dell'ordine



[http://](http://www.autopac.it)

www.autopac.it



Tel. 0521 699189



info@autopac.it